

STRENGTH 9000 SERIES TRAINING EQUIPMENT

SU86 Dip and Chin Assist

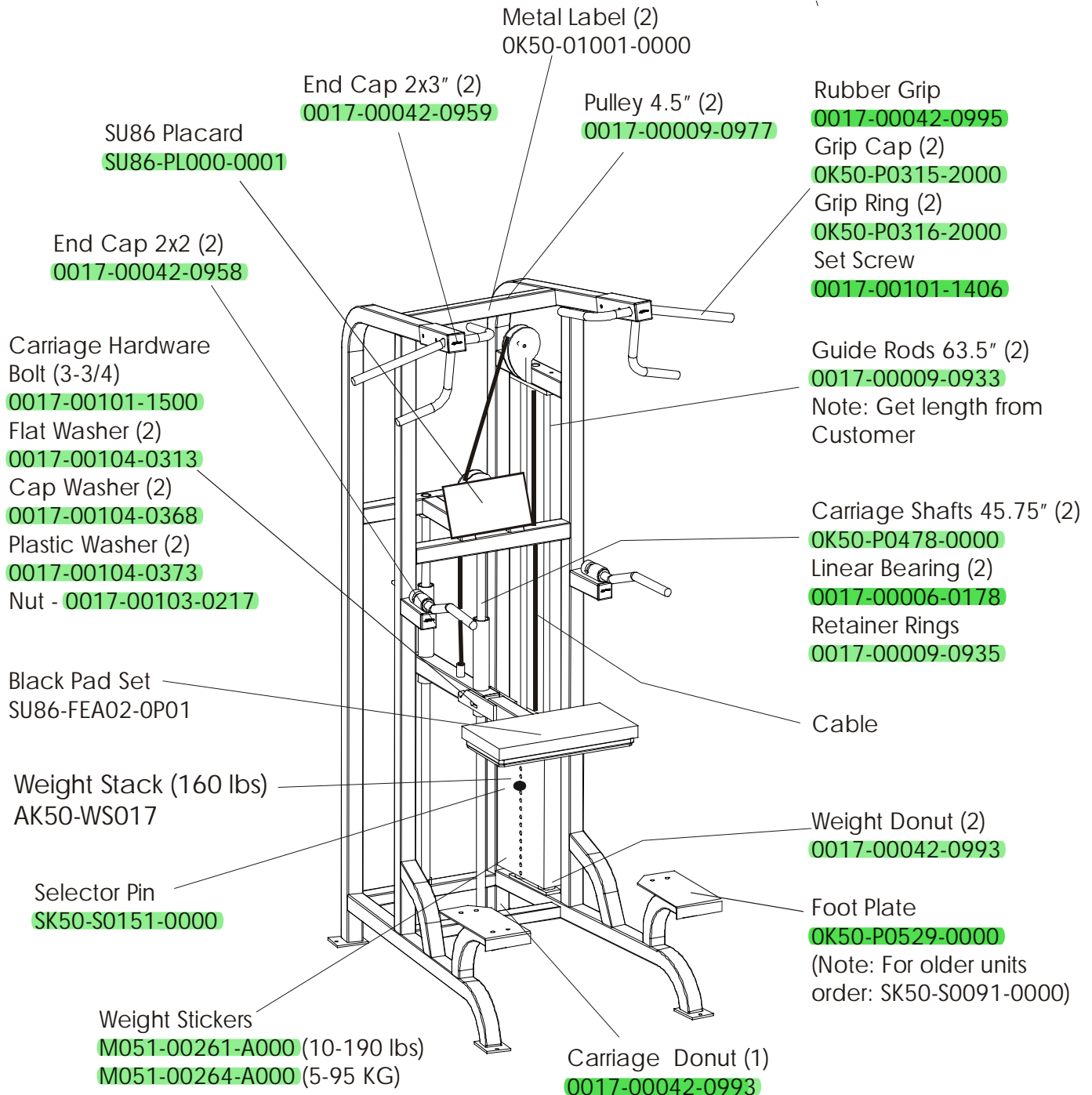

SU86 DIP AND CHIN ASSIST FRAME COMPONENTS

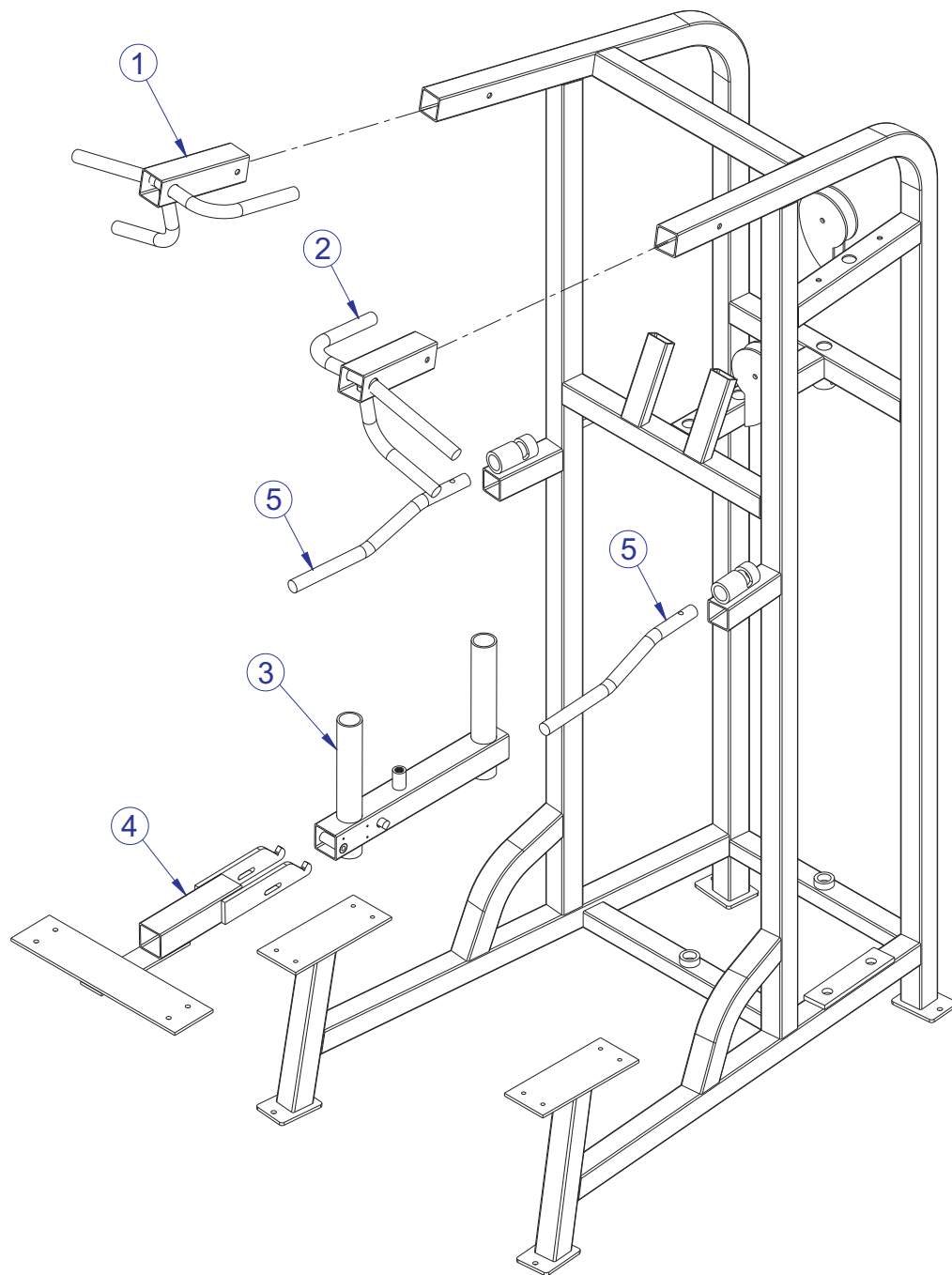

ITEM NO.	QTY.	PART NO.	DESCRIPTION
1	1	SU85-S0001-0000	HANDLE, UPPER DIP CHIN ASSIT LEFT
2	1	SU85-S0002-0000	HANDLE, DIP CHIN ASSIT UPPER RIGHT
3	1	SU85-S0003-0000	GUIDE, DIP CHIN ASSIT
4	1	SU85-S0004-0000	PLATFORM, DIP CHIN ASSIT
5	2	OK50-P0338-0000	HANDLE; STRENGTH

SU86 DIP AND CHIN ASSIST PLATFORM COMPONENTS

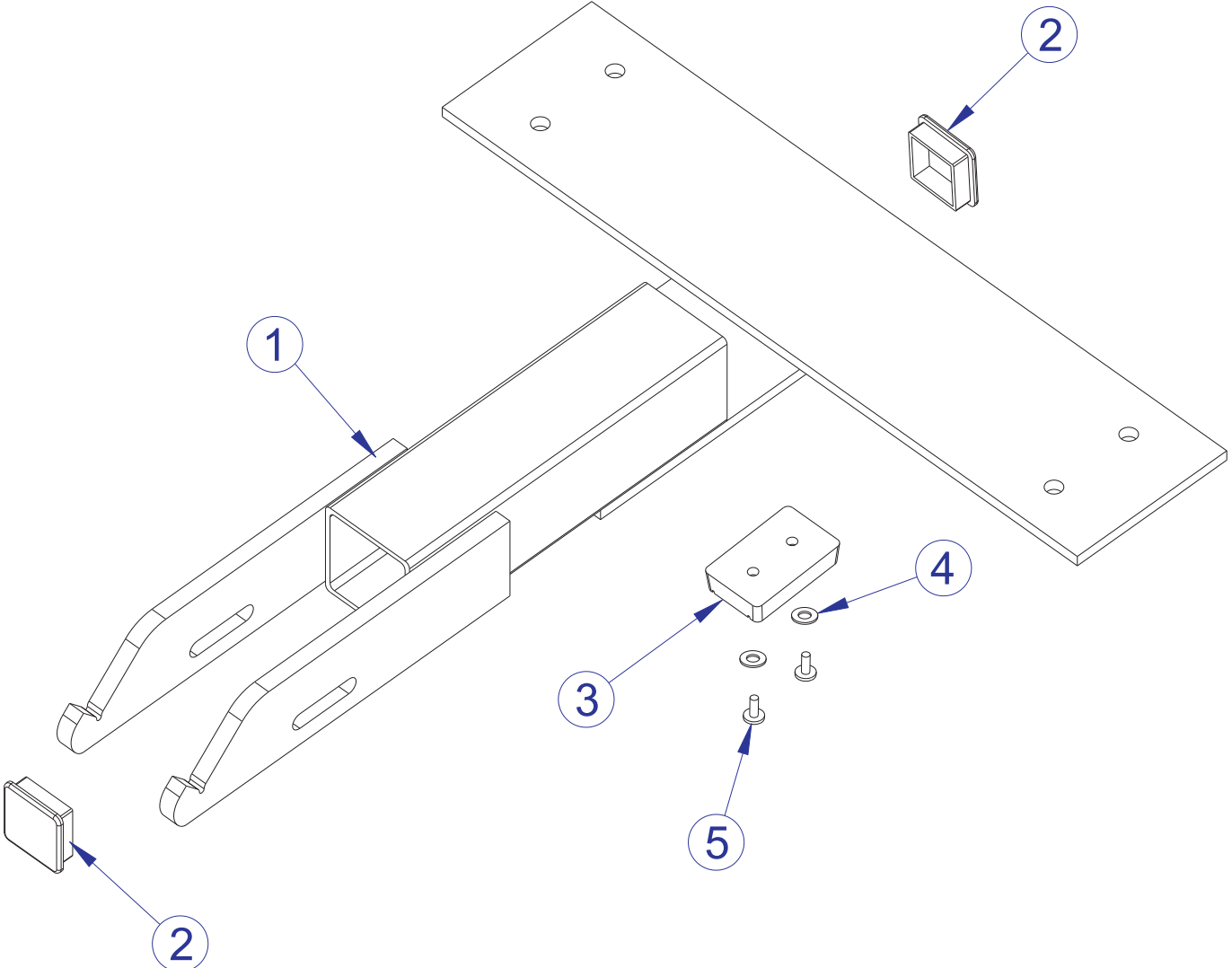

ITEM NO.	QTY.	PART NO.	DESCRIPTION
1	1	SU85-S0004-0000	PLATFORM, DIP CHIN ASSIT
2	2	0017-00042-0950	2 1/4 X 2 1/4 ENDCAP
3	1	0017-00042-1032	1.50 X 2.31 X .50 THK BUMPER
4	2	0017-00104-0310	WSH 10 200-.334-047 FL-D ST ZN B
5	2	0017-00101-1616	10-24X 8 PHL PAN ST ZN B